

# The Production of $^{53}\text{Mn}$ in a Fusion-Environment

C. Lederer<sup>a</sup>, A. Wallner<sup>a</sup>, I. Dillmann<sup>b</sup>, T. Faestermann<sup>b</sup>, A. Klix<sup>c</sup>,  
G. Korschinek<sup>b</sup>, J. Lachner<sup>b</sup>, M. Poutivtsev<sup>b</sup>, G. Rugel<sup>b</sup>, K. Seidel<sup>c</sup>, and H. Vonach<sup>a</sup>

<sup>a</sup>Isotopenforschung und Kernphysik, Fakultät für Physik, Universität Wien

<sup>b</sup>Physik Department, Technische Universität München

<sup>c</sup>Inst. f. Kern- und Teilchenphysik, TU Dresden und Forschungszentrum Dresden-Rossendorf

# Motivation

Reaction:

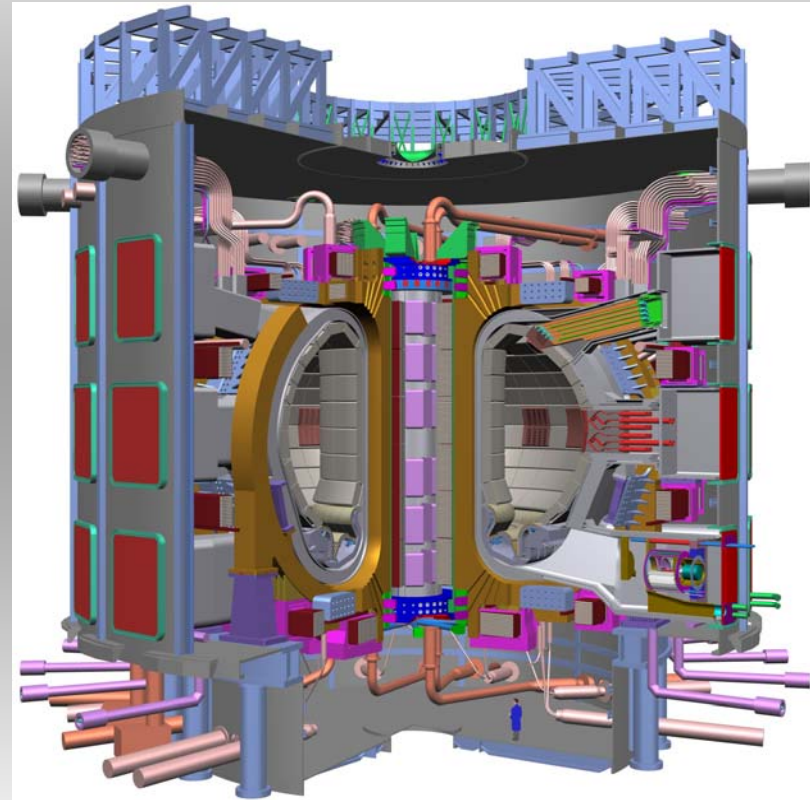

[http://ec.europa.eu/commission\\_barroso/potocnik/images/dossier/iter.jpg](http://ec.europa.eu/commission_barroso/potocnik/images/dossier/iter.jpg)

# Motivation

Reaction:

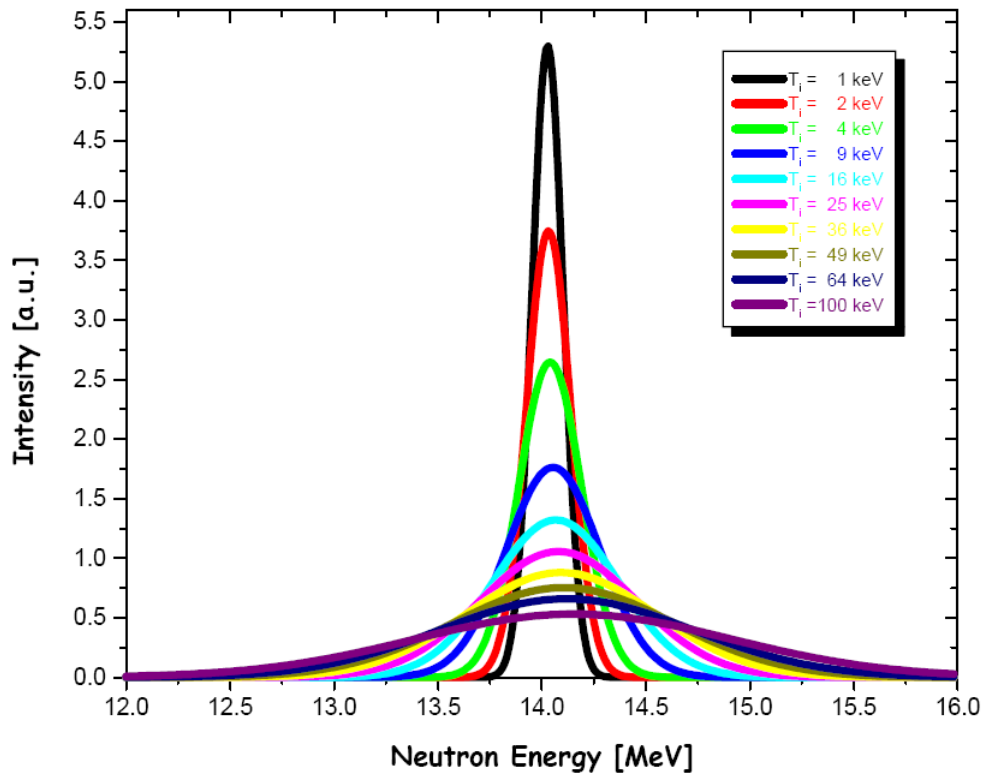

A. Wallner, 2000

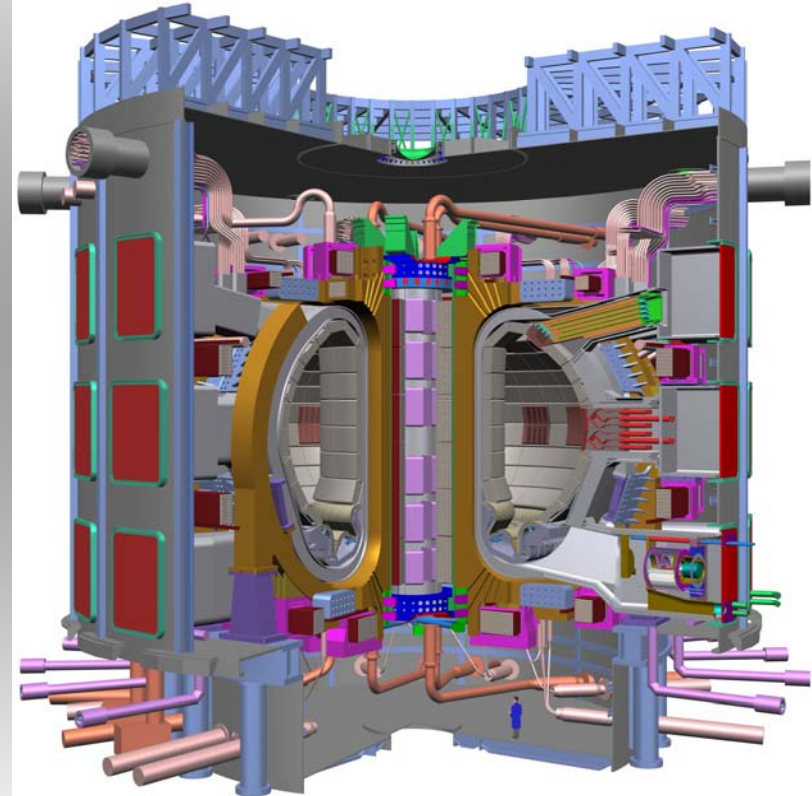

[http://ec.europa.eu/commission\\_barroso/potocnik/images/dossier/iter.jpg](http://ec.europa.eu/commission_barroso/potocnik/images/dossier/iter.jpg)

# Motivation

Reaction:

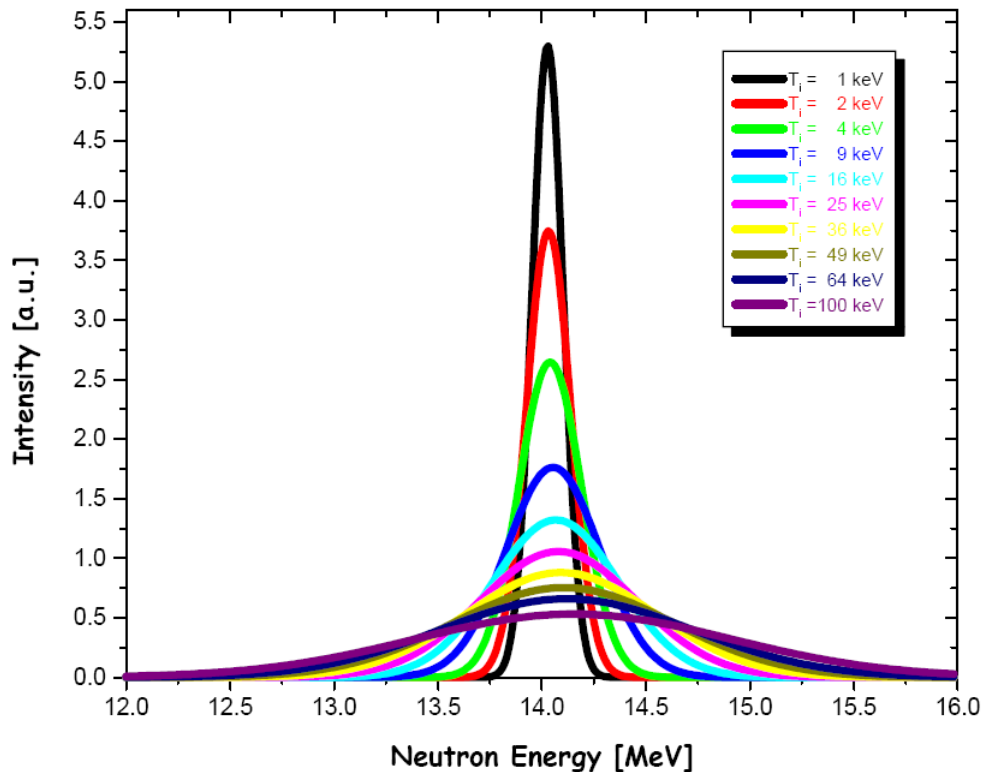

A. Wallner, 2000

Isotope	Half-life (y)	Reaction
$^{14}\text{C}$	5730	$^{14}\text{N}(n,p)$
$^{26}\text{Al}$	$7.2 \cdot 10^5$	$^{27}\text{Al}(n,2n)$
$^{53}\text{Mn}$	$3.7 \cdot 10^6$	$^{54}\text{Fe}(n,2n)$
		$^{54}\text{Fe}(n,np+d)$
$^{55}\text{Fe}$	2.73	$^{56}\text{Fe}(n,2n)$
$^{63}\text{Ni}$	100	$^{63}\text{Cu}(n,p)$
		$^{64}\text{Ni}(n,2n)$
$^{59}\text{Ni}$	$7.6 \cdot 10^4$	$^{60}\text{Ni}(n,2n)$
$^{93}\text{Zr}$	$1.5 \cdot 10^6$	$^{94}\text{Zr}(n,2n)$
		$^{93}\text{Nb}(n,p)$
$^{91}\text{Nb}$	680	$^{92}\text{Nb}(n,2n)$
$^{92}\text{Nb}$	$3.2 \cdot 10^7$	$^{93}\text{Nb}(n,2n)$
$^{93m}\text{Nb}$	16.1	$^{94}\text{Mo}(n,x)$
$^{94}\text{Nb}$	$2.0 \cdot 10^4$	$^{94}\text{Mo}(n,p)$
$^{93}\text{Mo}$	3500	$^{94}\text{Mo}(n,2n)$

# Motivation

Reaction:

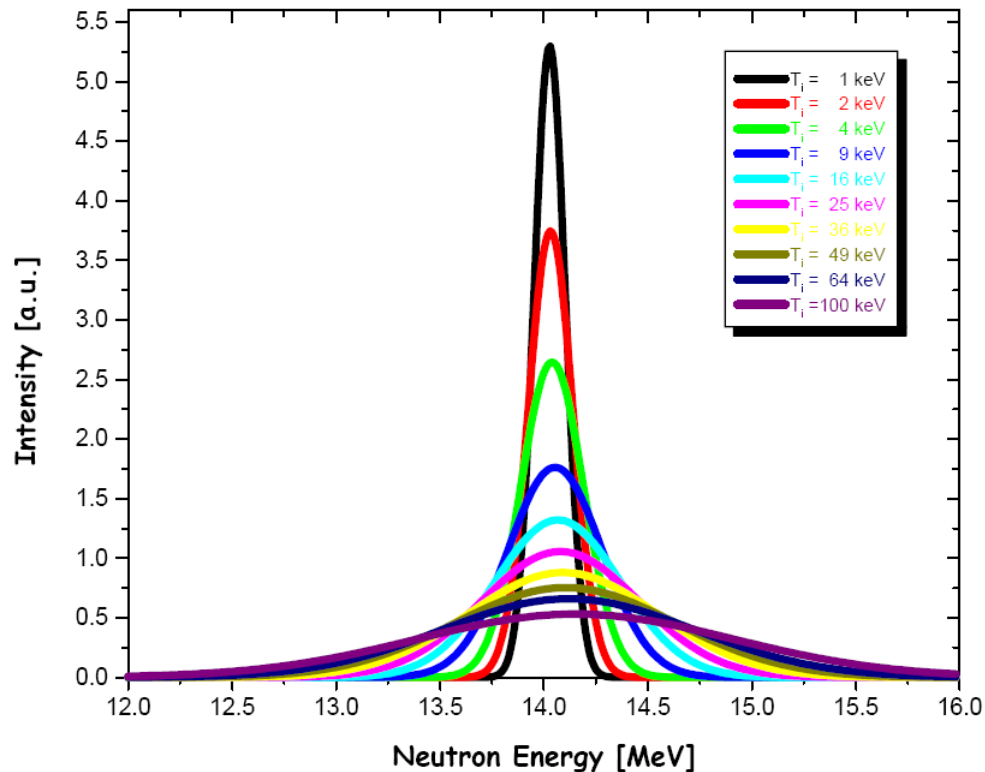

A. Wallner, 2000

Isotope	Half-life (y)	Reaction
$^{14}\text{C}$	5730	$^{14}\text{N}(n,p)$
$^{26}\text{Al}$	$7.2 \cdot 10^5$	$^{27}\text{Al}(n,2n)$
$^{53}\text{Mn}$	$3.7 \cdot 10^6$	$^{54}\text{Fe}(n,2n)$
		$^{54}\text{Fe}(n,np+d)$
$^{55}\text{Fe}$	2.73	$^{56}\text{Fe}(n,2n)$
$^{63}\text{Ni}$	100	$^{63}\text{Cu}(n,p)$
		$^{64}\text{Ni}(n,2n)$
$^{59}\text{Ni}$	$7.6 \cdot 10^4$	$^{60}\text{Ni}(n,2n)$
$^{93}\text{Zr}$	$1.5 \cdot 10^6$	$^{94}\text{Zr}(n,2n)$
		$^{93}\text{Nb}(n,p)$
$^{91}\text{Nb}$	680	$^{92}\text{Nb}(n,2n)$
$^{92}\text{Nb}$	$3.2 \cdot 10^7$	$^{93}\text{Nb}(n,2n)$
$^{93m}\text{Nb}$	16.1	$^{94}\text{Mo}(n,x)$
$^{94}\text{Nb}$	$2.0 \cdot 10^4$	$^{94}\text{Mo}(n,p)$
$^{93}\text{Mo}$	3500	$^{94}\text{Mo}(n,2n)$

# Available data for $^{54}\text{Fe}(n,np+d)^{53}\text{Mn}$ cross-sections

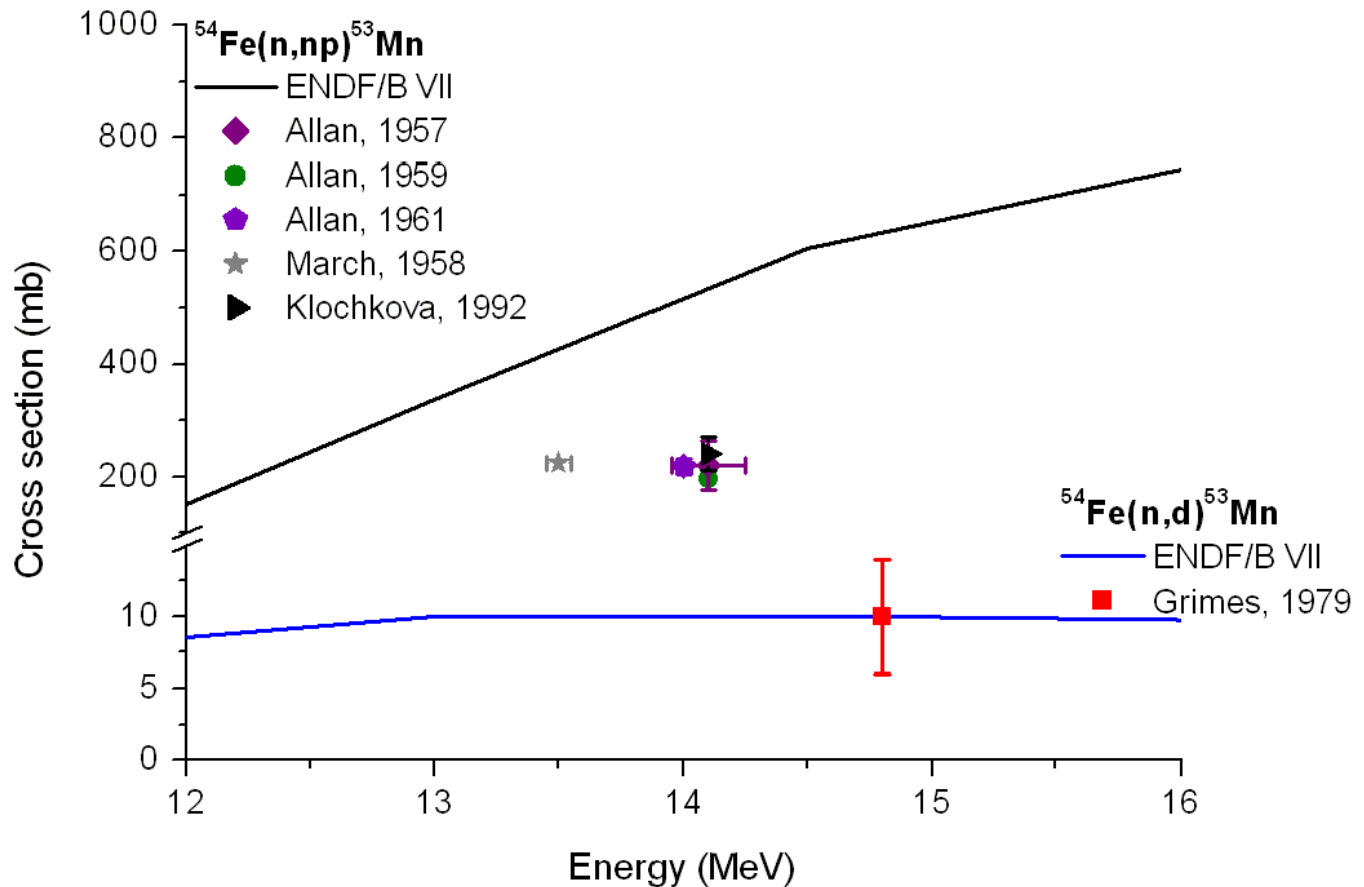

<http://www-nds.iaea.org/>

# Cross-section determination



# Cross-section determination

- Irradiation of highly enriched  $^{54}\text{Fe}$  with quasi-monoenergetic neutrons from 13-15 MeV at FZD



# Cross-section determination

- Irradiation of highly enriched  $^{54}\text{Fe}$  with quasi-monoenergetic neutrons from 13-15 MeV at FZD
- Adding stable  $^{55}\text{Mn}$  as spike



# Cross-section determination

- Irradiation of highly enriched  $^{54}\text{Fe}$  with quasi-monoenergetic neutrons from 13-15 MeV at FZD
- Adding stable  $^{55}\text{Mn}$  as spike
- Chemical removal of Fe and other impurities from sample

# Cross-section determination

- Irradiation of highly enriched  $^{54}\text{Fe}$  with quasi-monoenergetic neutrons from 13-15 MeV at FZD
- Adding stable  $^{55}\text{Mn}$  as spike
- Chemical removal of Fe and other impurities from sample
- Measurement of  $^{53}\text{Mn} / ^{55}\text{Mn}$  with AMS at MLL Munich



# Cross-section determination

- Irradiation of highly enriched  $^{54}\text{Fe}$  with quasi-monoenergetic neutrons from 13-15 MeV at FZD
- Adding stable  $^{55}\text{Mn}$  as spike
- Chemical removal of Fe and other impurities from sample
- Measurement of  $^{53}\text{Mn} / ^{55}\text{Mn}$  with AMS at MLL Munich

$$N_{^{53}\text{Mn}} = N_{^{54}\text{Fe}} \cdot \phi \cdot \sigma(E_n) \cdot f$$



# Cross-section determination

- Irradiation of highly enriched  $^{54}\text{Fe}$  with quasi-monoenergetic neutrons from 13-15 MeV at FZD
- Adding stable  $^{55}\text{Mn}$  as spike
- Chemical removal of Fe and other impurities from sample
- Measurement of  $^{53}\text{Mn} / ^{55}\text{Mn}$  with AMS at MLL Munich

$$N_{^{53}\text{Mn}} = N_{^{54}\text{Fe}} \cdot \phi \cdot \sigma(E_n) \cdot f$$

$$\rightarrow \sigma(E_n) = \frac{N_{^{53}\text{Mn}}}{N_{^{55}\text{Mn}}} \frac{N_{^{55}\text{Mn}}}{N_{^{54}\text{Fe}}} \frac{1}{\phi \cdot f}$$

# Cross-section determination

- Irradiation of highly enriched  $^{54}\text{Fe}$  with quasi-monoenergetic neutrons from 13-15 MeV at FZD
- Adding stable  $^{55}\text{Mn}$  as spike
- Chemical removal of Fe and other impurities from sample
- Measurement of  $^{53}\text{Mn} / ^{55}\text{Mn}$  with AMS at MLL Munich

$$N_{^{53}\text{Mn}} = N_{^{54}\text{Fe}} \cdot \phi \cdot \sigma(E_n) \cdot f$$

$$\rightarrow \sigma(E_n) = \frac{N_{^{53}\text{Mn}}}{N_{^{55}\text{Mn}}} \frac{N_{^{55}\text{Mn}}}{N_{^{54}\text{Fe}}} \frac{1}{\phi \cdot f}$$

AMS

# Cross-section determination

- Irradiation of highly enriched  $^{54}\text{Fe}$  with quasi-monoenergetic neutrons from 13-15 MeV at FZD
- Adding stable  $^{55}\text{Mn}$  as spike
- Chemical removal of Fe and other impurities from sample
- Measurement of  $^{53}\text{Mn} / ^{55}\text{Mn}$  with AMS at MLL Munich

$$N_{^{53}\text{Mn}} = N_{^{54}\text{Fe}} \cdot \phi \cdot \sigma(E_n) \cdot f$$

$$\rightarrow \sigma(E_n) = \frac{N_{^{53}\text{Mn}}}{N_{^{55}\text{Mn}}} \cdot \frac{N_{^{55}\text{Mn}}}{N_{^{54}\text{Fe}}} \cdot \frac{1}{\phi \cdot f}$$

AMS

mass measurement

# Cross-section determination

- Irradiation of highly enriched  $^{54}\text{Fe}$  with quasi-monoenergetic neutrons from 13-15 MeV at FZD
- Adding stable  $^{55}\text{Mn}$  as spike
- Chemical removal of Fe and other impurities from sample
- Measurement of  $^{53}\text{Mn} / ^{55}\text{Mn}$  with AMS at MLL Munich

$$N_{^{53}\text{Mn}} = N_{^{54}\text{Fe}} \cdot \phi \cdot \sigma(E_n) \cdot f$$

$$\rightarrow \sigma(E_n) = \frac{N_{^{53}\text{Mn}}}{N_{^{55}\text{Mn}}} \cdot \frac{N_{^{55}\text{Mn}}}{N_{^{54}\text{Fe}}} \cdot \frac{1}{\phi \cdot f}$$

AMS ← mass measurement ← monitor reactions



# Neutron Irradiations



# Neutron Irradiations

- Neutron generator at Forschungszentrum Dresden:  $t(d,n)^4\text{He}$
- 11 positions with  $^{13}\text{C}$ ,  $^{14}\text{N}$ ,  $^{54}\text{Fe}$ ,  $^{\text{nat}}\text{Fe}$  samples
- 4 positions for  $^{54}\text{Fe}(n,np+d) ^{53}\text{Mn}$

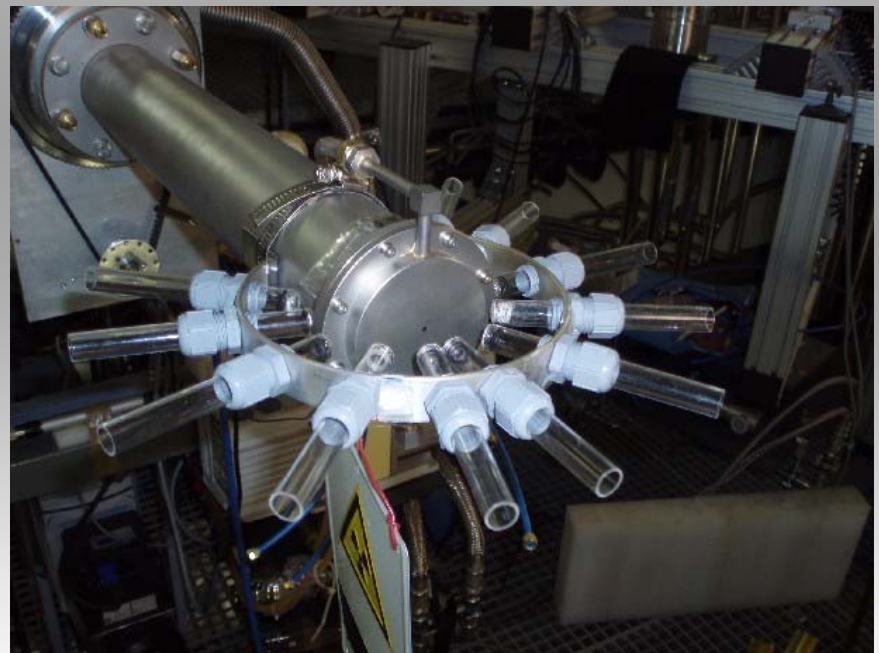

# Neutron Irradiations

- Neutron generator at Forschungszentrum Dresden:  $t(d,n)^4\text{He}$
- 11 positions with  $^{13}\text{C}$ ,  $^{14}\text{N}$ ,  $^{54}\text{Fe}$ ,  $^{\text{nat}}\text{Fe}$  samples
- 4 positions for  $^{54}\text{Fe}(n,np+d)^{53}\text{Mn}$

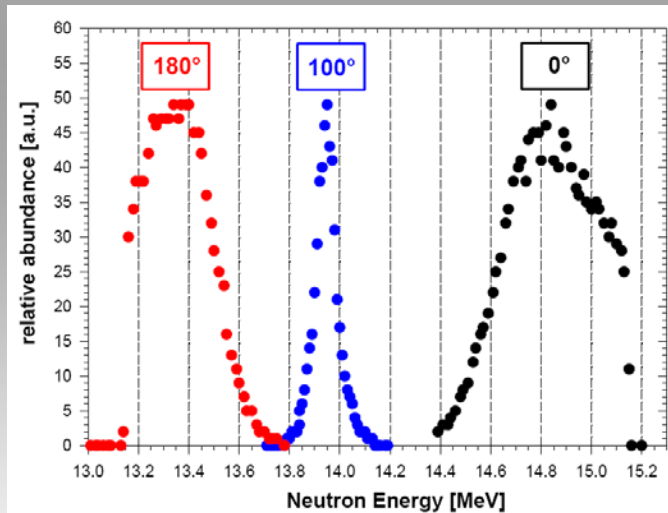

A. Wallner, 2000

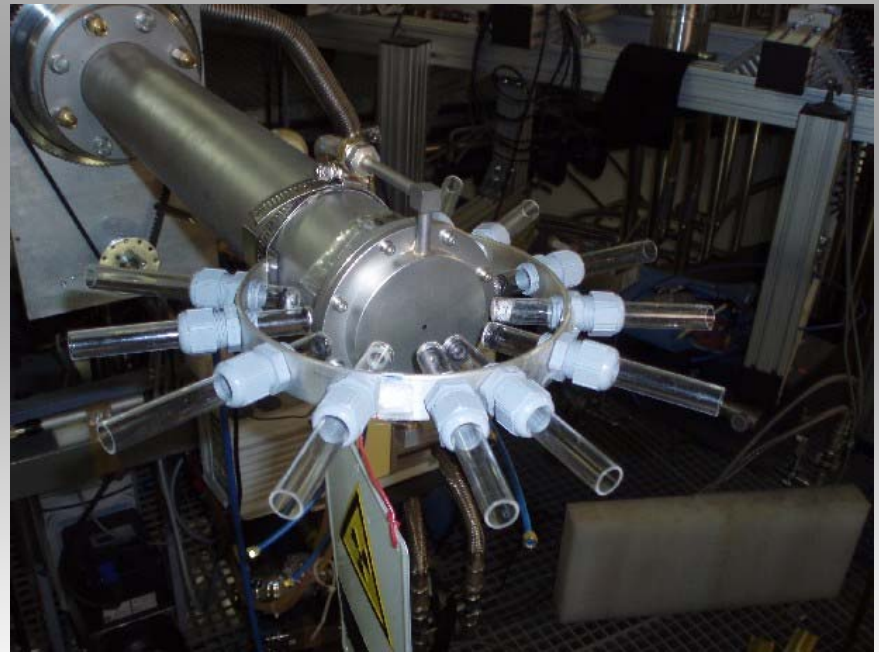

# Neutron Irradiations

- Neutron generator at Forschungszentrum Dresden:  $t(d,n)^4\text{He}$
- 11 positions with  $^{13}\text{C}$ ,  $^{14}\text{N}$ ,  $^{54}\text{Fe}$ ,  $^{\text{nat}}\text{Fe}$  samples
- 4 positions for  $^{54}\text{Fe}(n,np+d) ^{53}\text{Mn}$

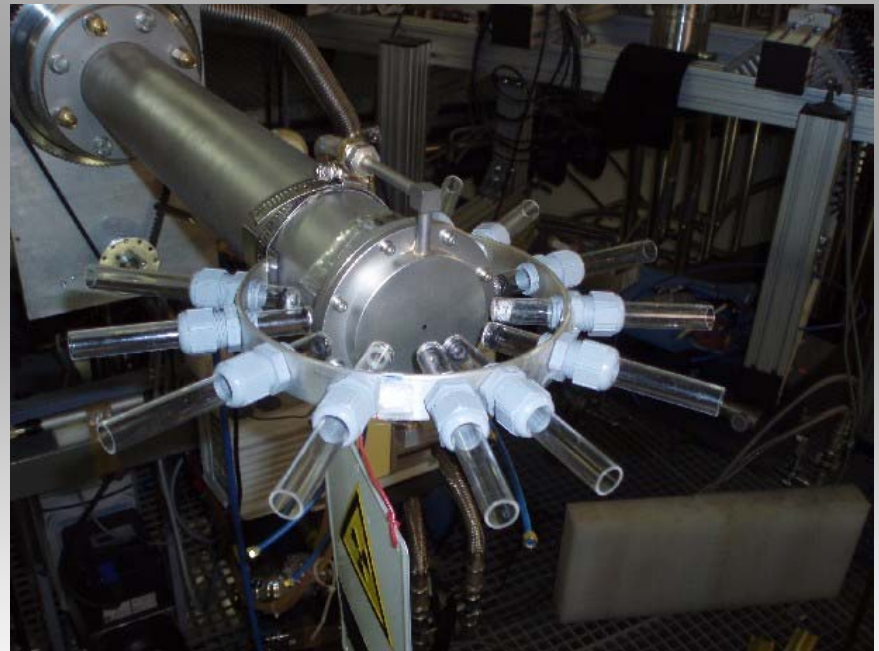
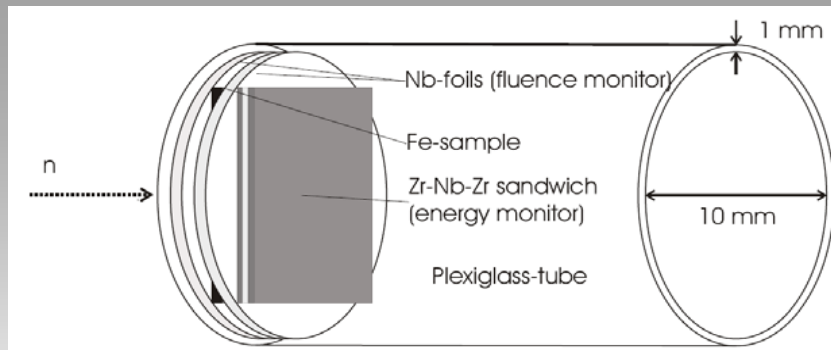



# $^{53}\text{Mn}/^{55}\text{Mn}$ measurements with AMS

(AMS....Accelerator Mass Spectrometry)



# $^{53}\text{Mn}/^{55}\text{Mn}$ measurements with AMS

(AMS....Accelerator Mass Spectrometry)

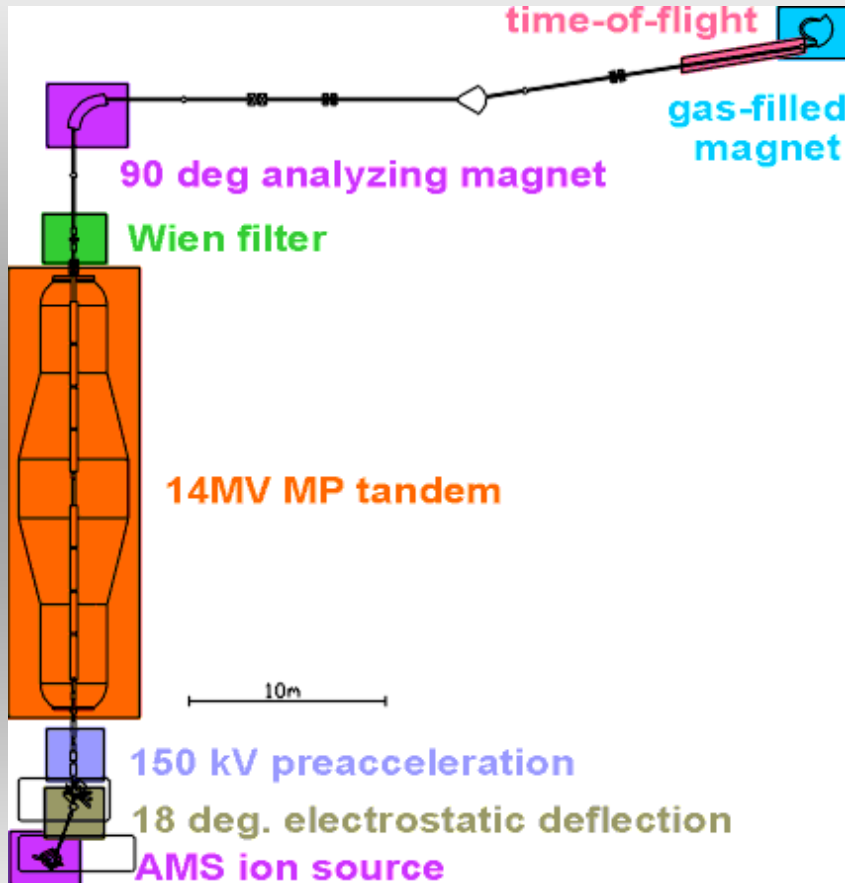

Munich 14 MV tandem accelerator



# $^{53}\text{Mn}/^{55}\text{Mn}$ measurements with AMS

(AMS....Accelerator Mass Spectrometry)

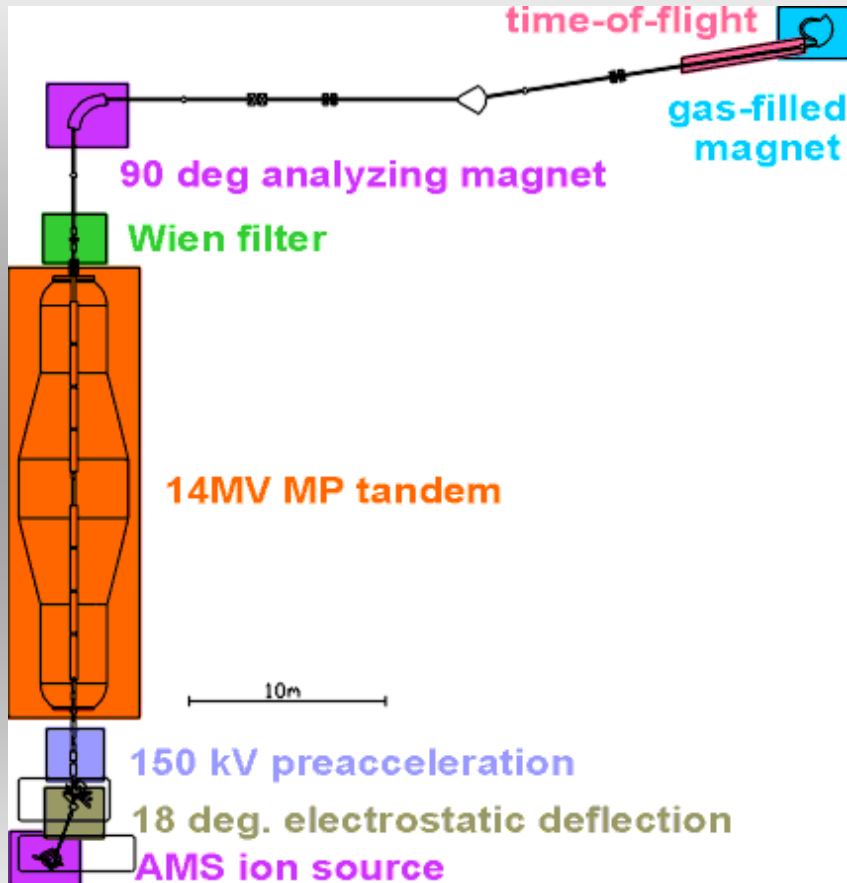

$^{53}\text{Mn}$  - stable isobar  $^{53}\text{Cr}$

Munich 14 MV tandem accelerator

# Isobar suppression: GAMS

- GAMS.... Gas-filled Analyzing Magnet System





# Isobar suppression: GAMS

- GAMS.... Gas-filled Analyzing Magnet System
- Principle:

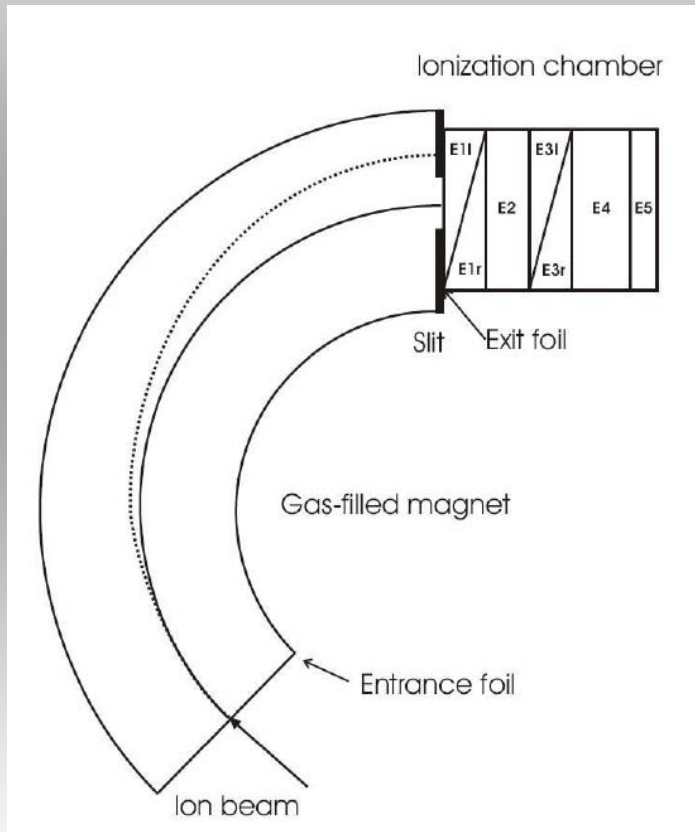

# Isobar suppression: GAMS

- GAMS.... Gas-filled Analyzing Magnet System
- Principle:

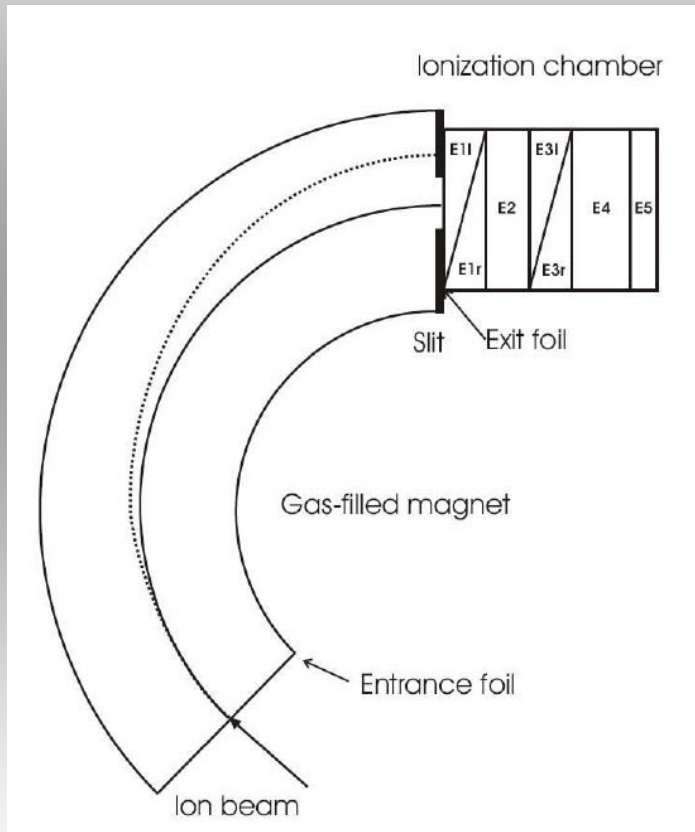

Cr-suppression:

- Magnet:  $10^3$
- Ionization chamber:  $10^6$

[fwd](#)

# Results

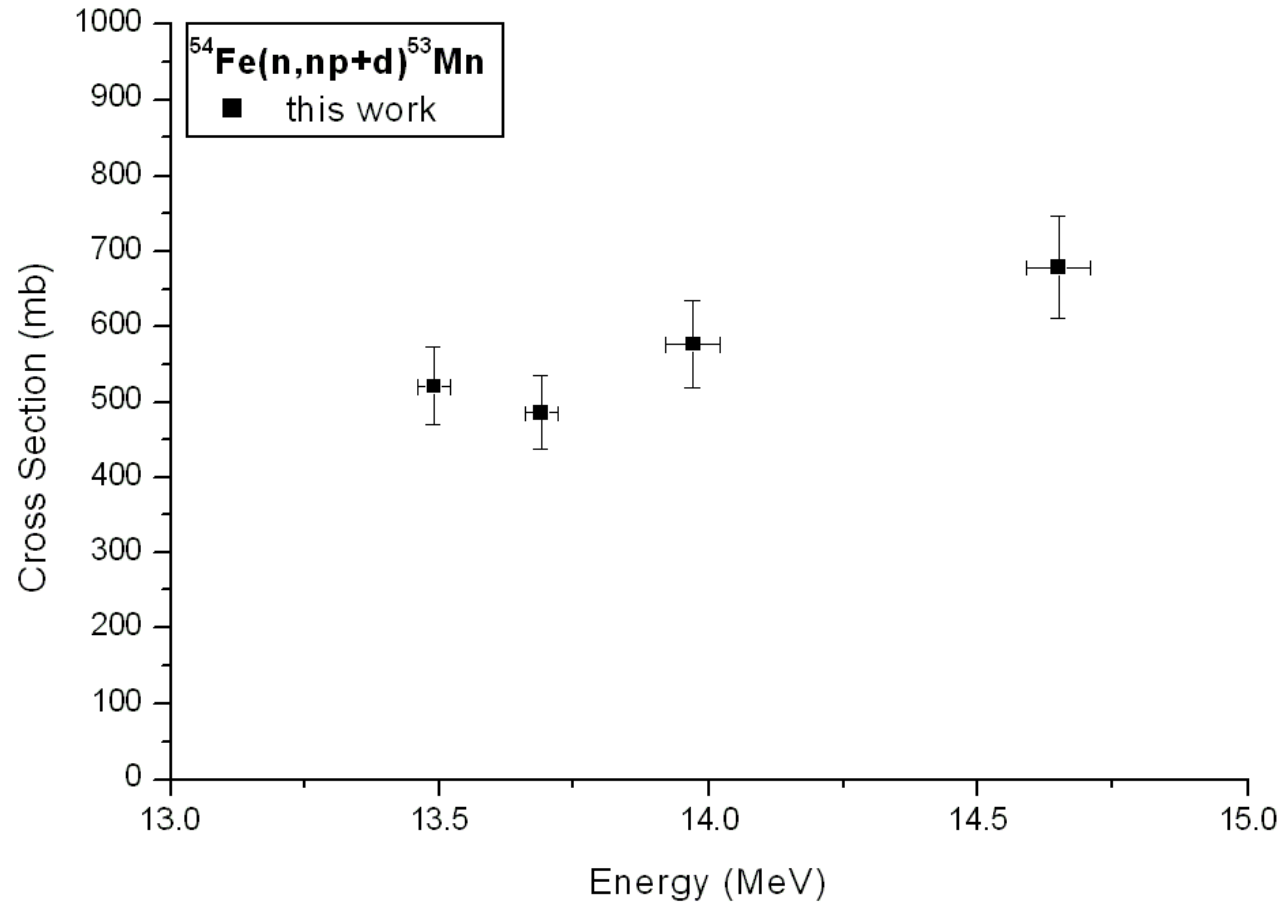

# Results

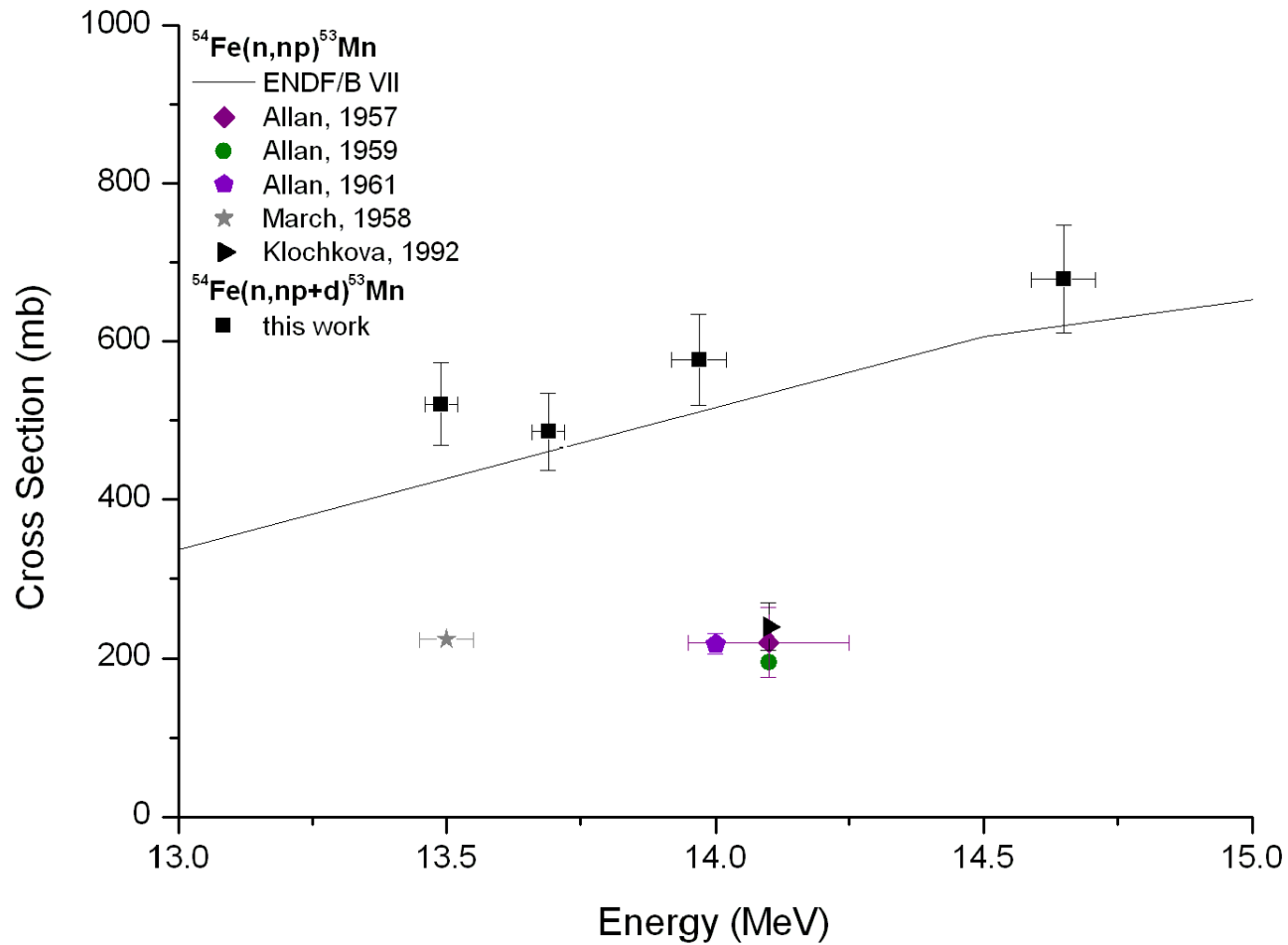

# Results

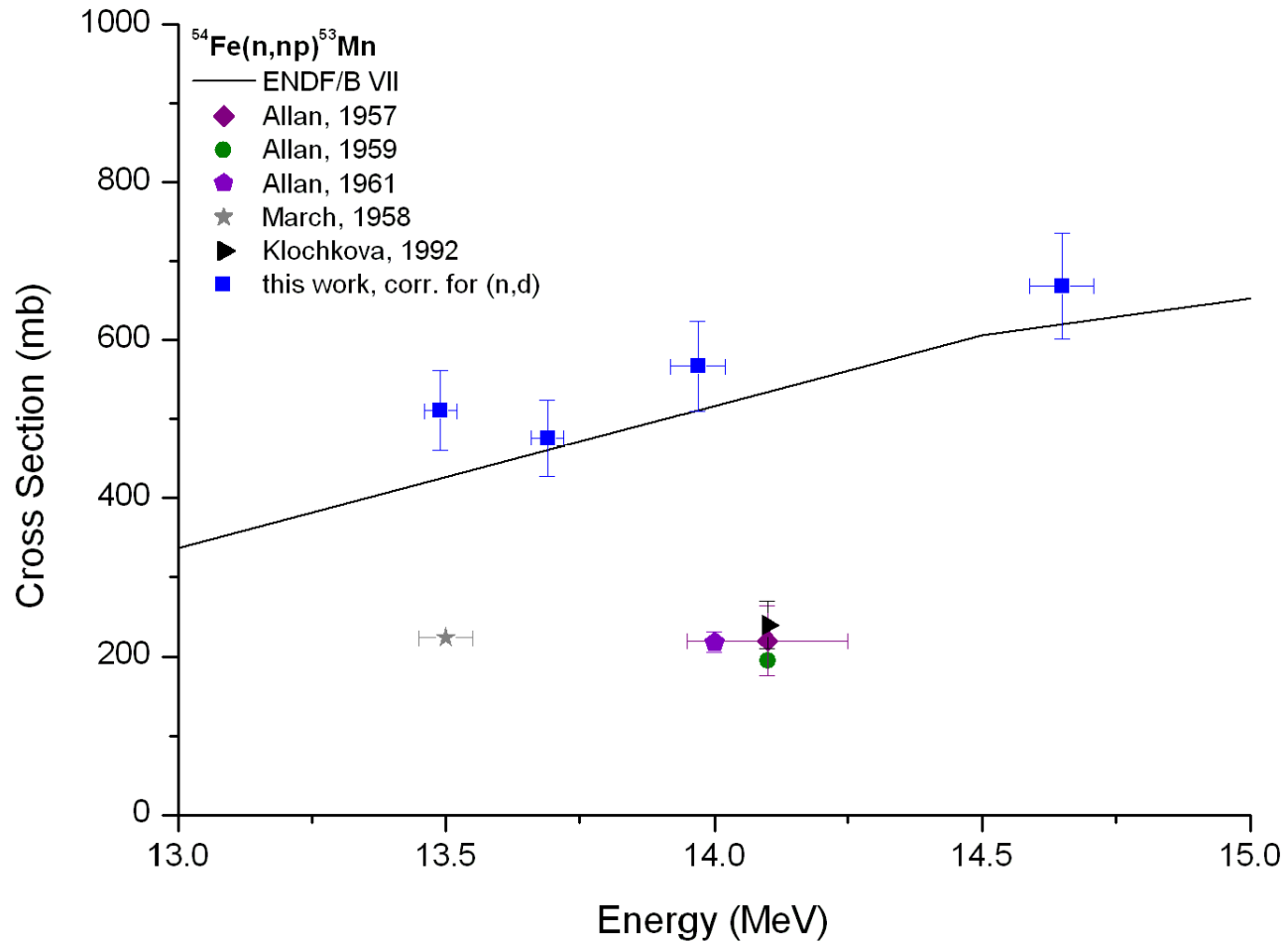

Thank you!

# Reference Material

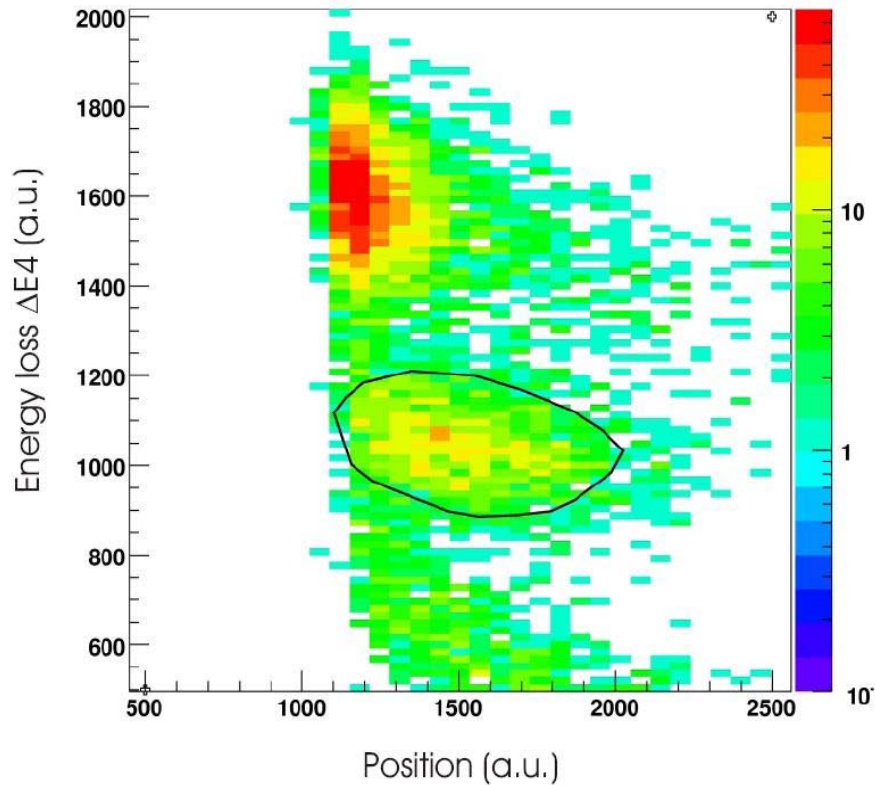

# Reference Material

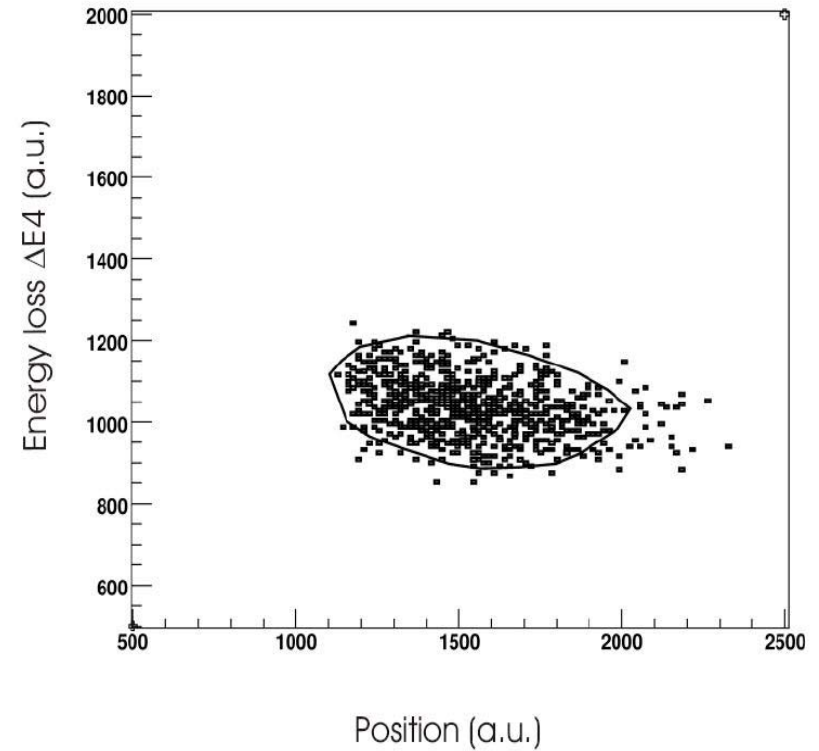
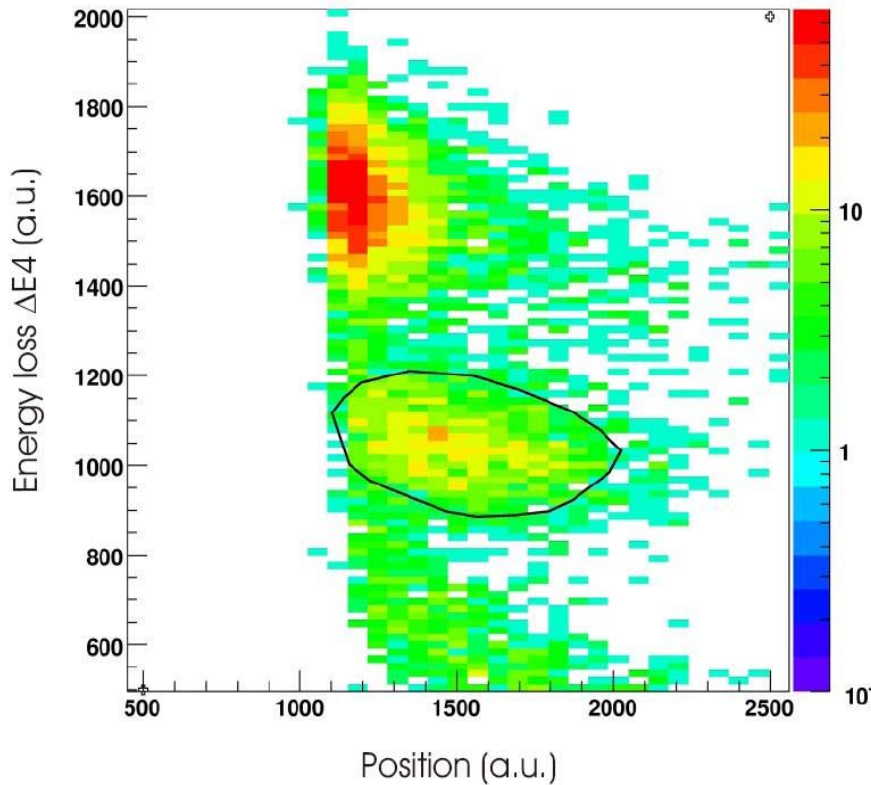



# Cr-blank: $^{55}\text{Mn}$ with 1000 ppm $^{53}\text{Cr}$

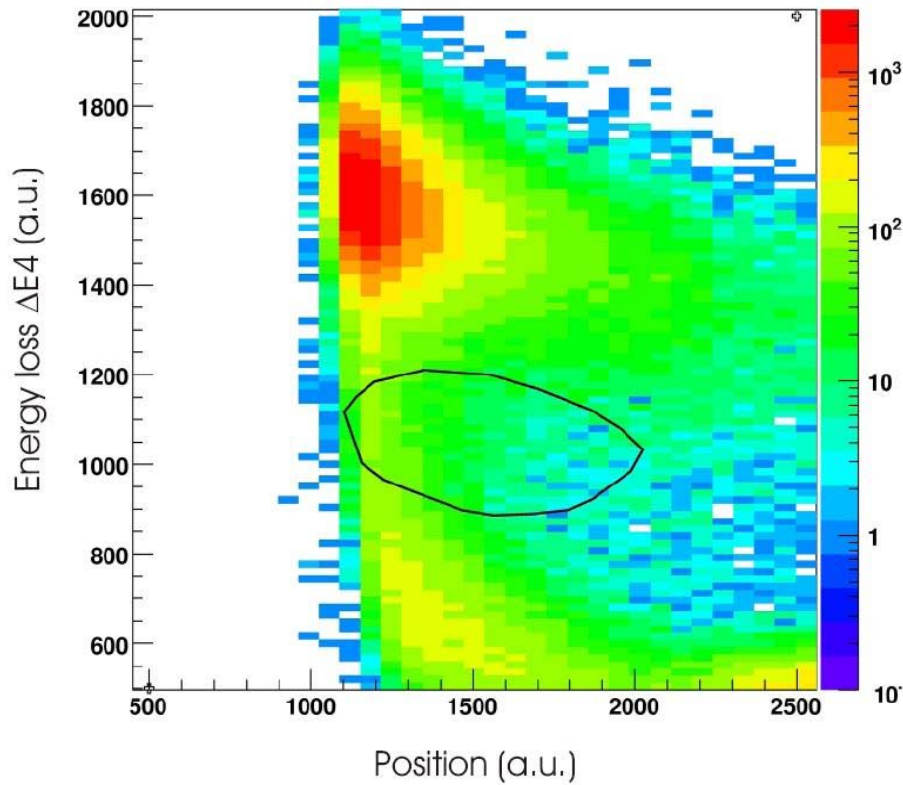

# Cr-blank: $^{55}\text{Mn}$ with 1000 ppm $^{53}\text{Cr}$

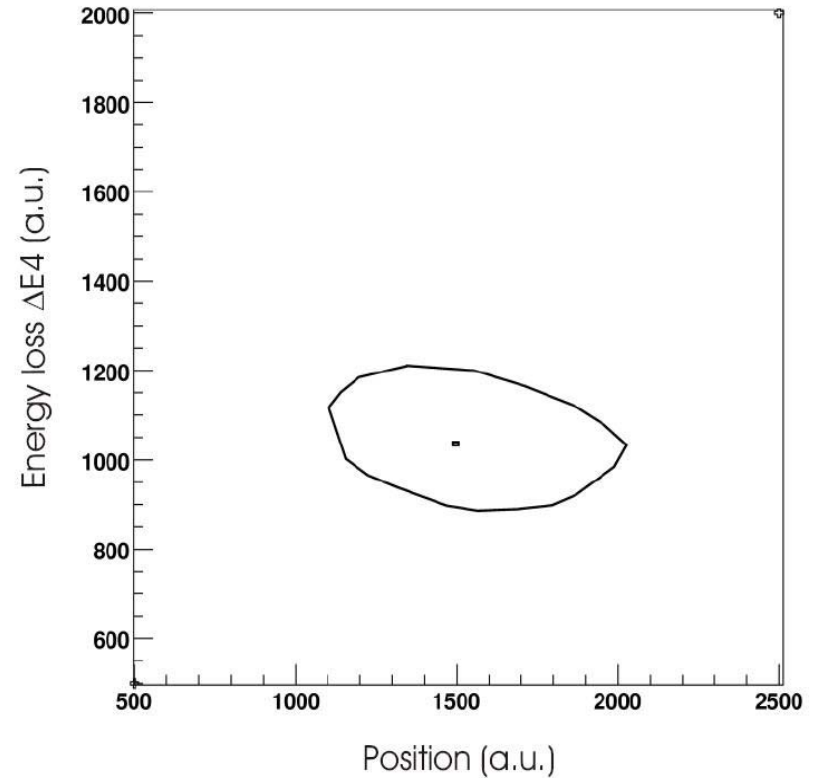
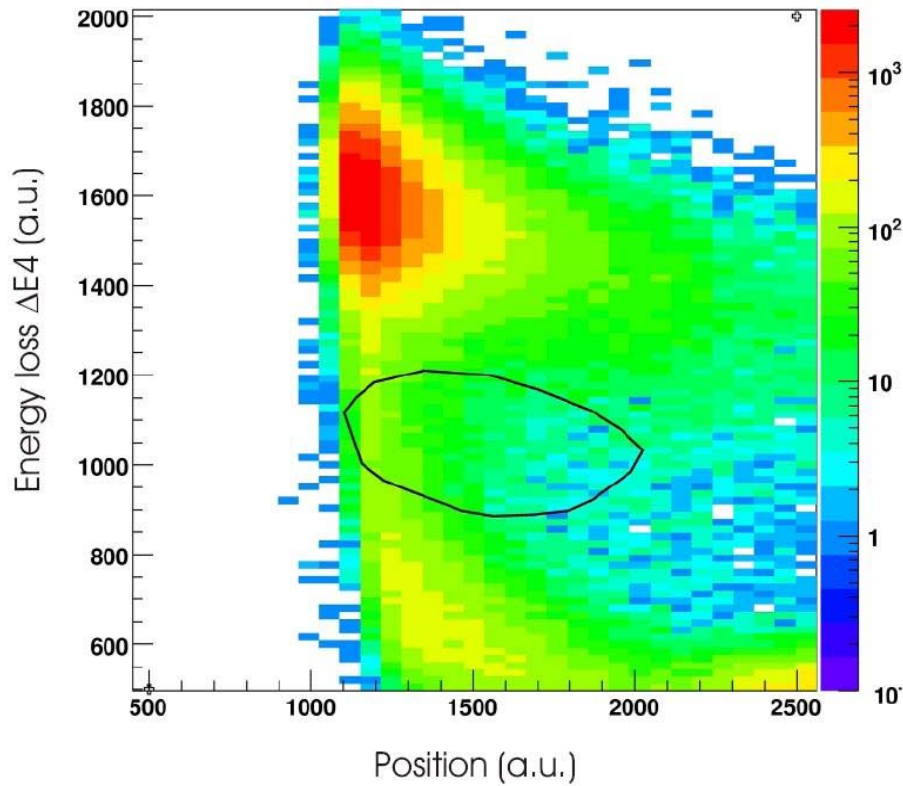

# Cr-blank: $^{55}\text{Mn}$ with 1000 ppm $^{53}\text{Cr}$

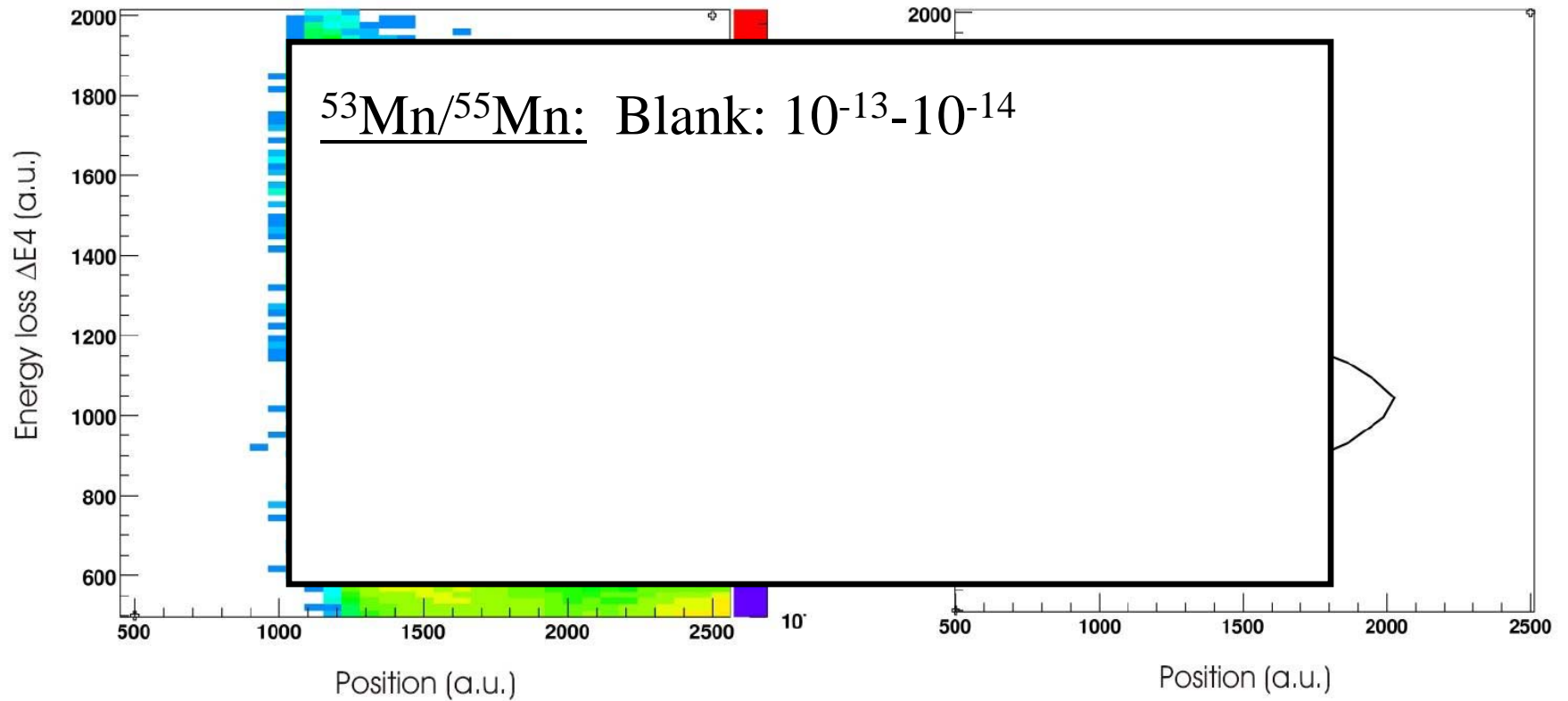

# Cr-blank: $^{55}\text{Mn}$ with 1000 ppm $^{53}\text{Cr}$

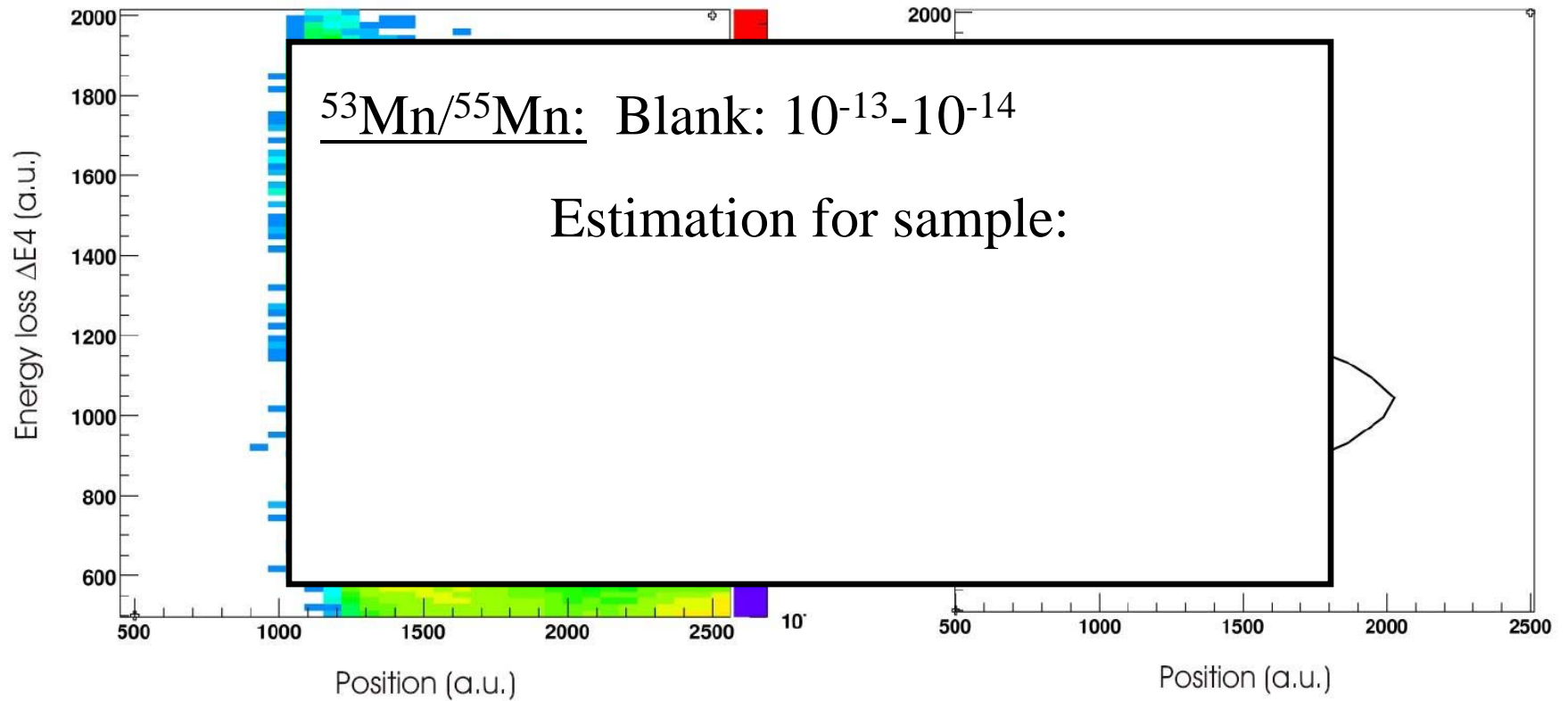

# Cr-blank: $^{55}\text{Mn}$ with 1000 ppm $^{53}\text{Cr}$

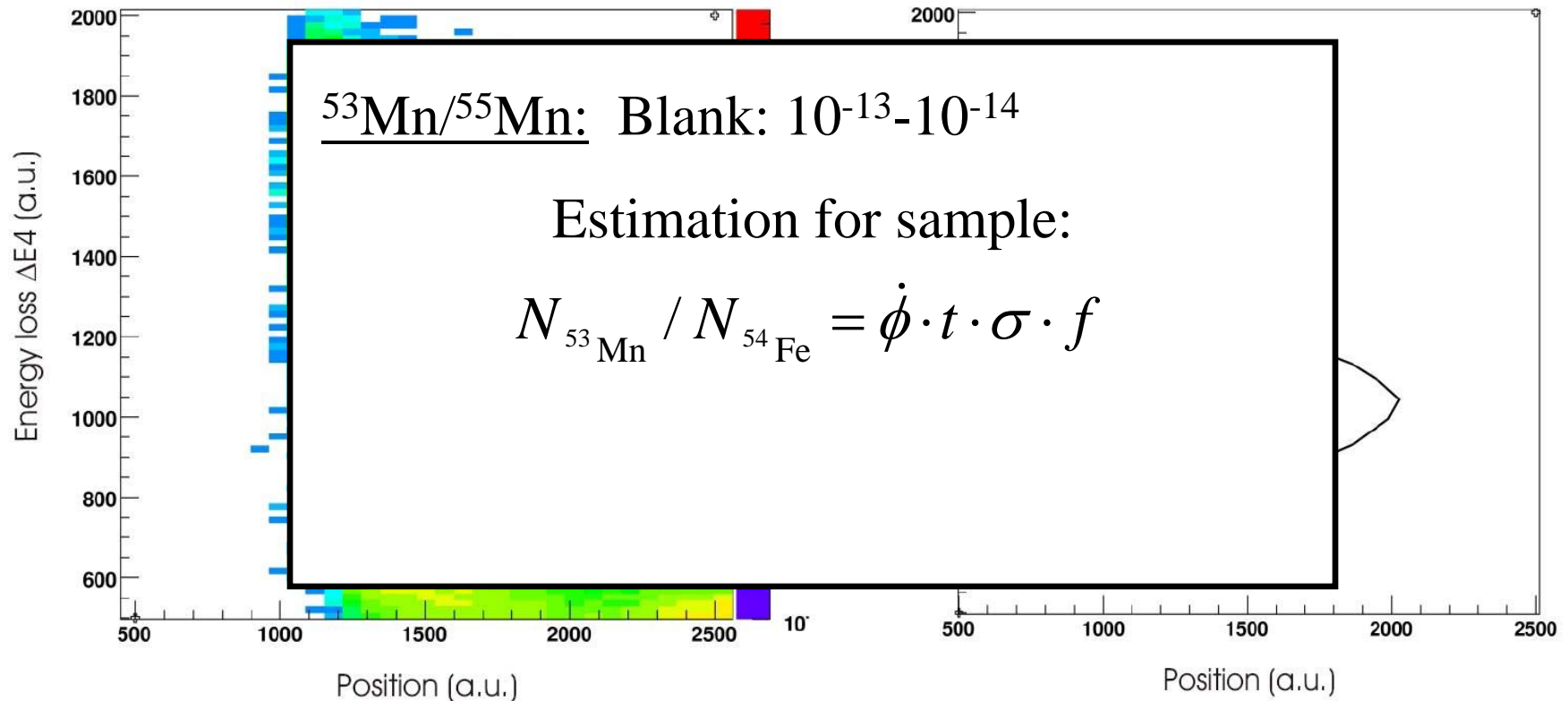

# Cr-blank: $^{55}\text{Mn}$ with 1000 ppm $^{53}\text{Cr}$

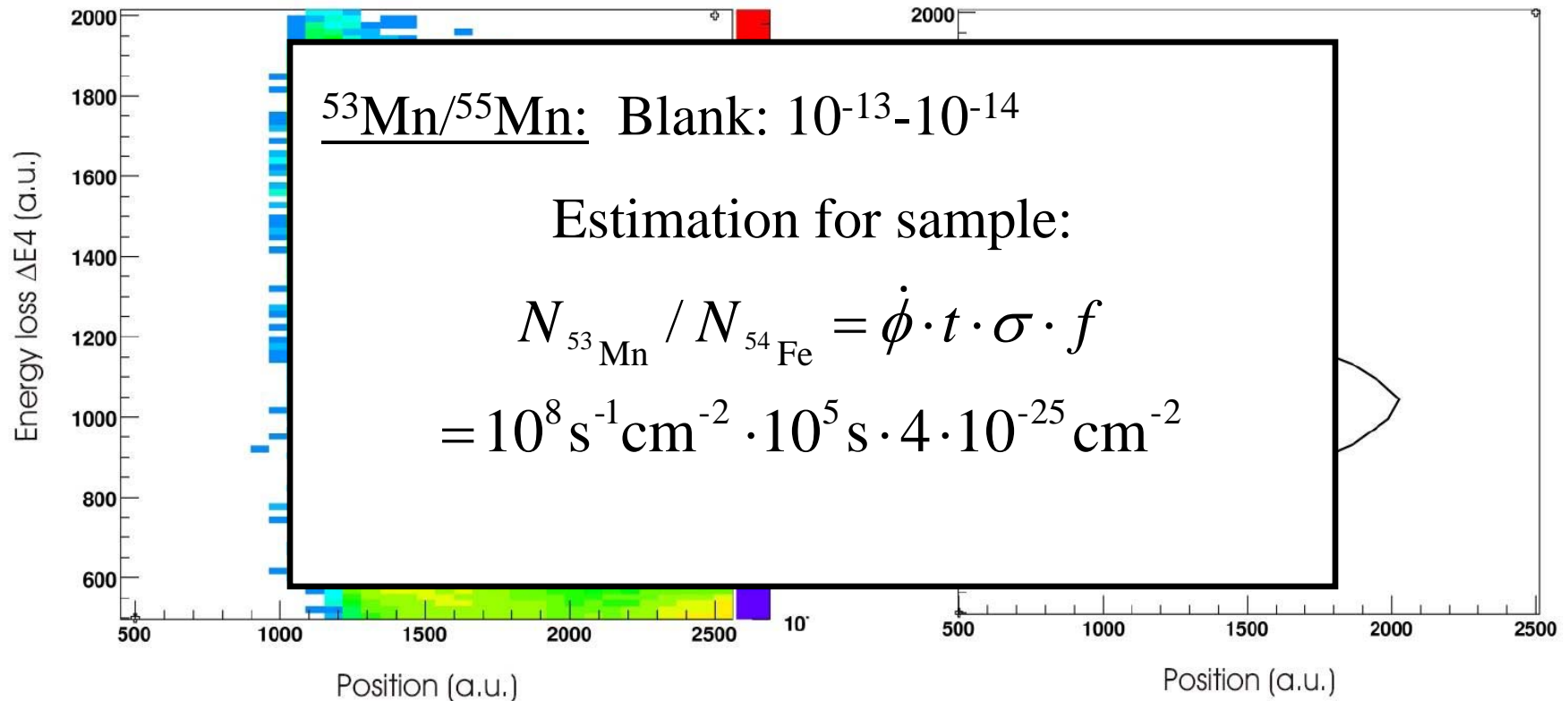

# Cr-blank: $^{55}\text{Mn}$ with 1000 ppm $^{53}\text{Cr}$

